

Serie Sliding

SR328B

Nylon Sliding Cable Chain with un-screwable aluminium rods

Inner height (D) 48 mm

Strong double share Sideband & Frame construction with large anti-friction triple-pin. The chain incorporates large sliding-skid surfaces to offer durability, even with high speed/loads. The Alu-rod frames are un-screwable from inner and outer radius. As standard the chain comes with frames every second link, on request with frames every link. Separator systems are available.

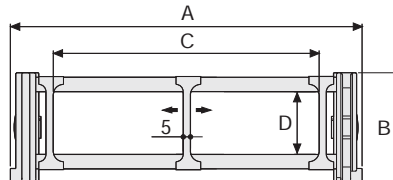

Separator

- Unassembled	Part.no S3000F
- Assembled	Part.no S3000FMC

Pin

Part.no PG328TP

Technical characteristics

Speed	3,5 m/s
Acceleration	8 m/s ²

For higher requirements please consult our technical dept.

A	B	C	D	R	Weight/m	Chain
mm	mm	mm	mm	mm	kg	Part Number
162	79	100	48	150-180-200-230-280-400	2,50	SR328B100□□□*
212	79	150	48	150-180-200-230-280-400	2,60	SR328B150□□□*
262	79	200	48	150-180-200-230-280-400	2,75	SR328B200□□□*
312	79	250	48	150-180-200-230-280-400	2,90	SR328B250□□□*
362	79	300	48	150-180-200-230-280-400	3,00	SR328B300□□□*
C+62	79	48	150-180-200-230-280-400		SR328B □□□□□**

*Complete the code by inserting the value of the radius (R): Ex. SR328B100 □ □ □ □

**Complete the code by inserting the value of the quote C and the radius (R): Ex. SR328B □ □ □ □ □ □ □ □ □ □
Chain equipped with aluminium rods every pitch: complete the code by inserting the letter D.
Ex. SR328B100150 □

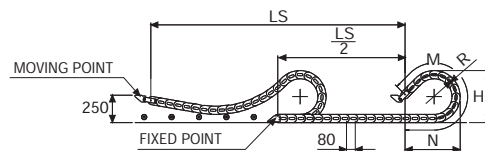

R	H	N	M
mm	mm	mm	mm
150	375	425	955
180	435	530	1220
200	475	600	1395
230	535	700	1655
280	635	875	2095
400	875	1285	3145

Length of chain (L)

Half travel distance ($\frac{LS}{2}$)

plus length of curve (M)

$$L = \frac{LS}{2} + M$$



Version with Alu-rods on every second pitch.

Serie Sliding

SR328B
Nylon Sliding Cable
Chain
with un-screwable
aluminium rods

End Brackets

The end brackets set allows the two ends of the chain to be attached to the equipment. One set comprises two movable end brackets to install at the moving point and two standard steel end brackets to install at the fixed point.

**Bright Zinc Plated Steel
Movable Type*
(moving point)**

**Bright Zinc Plated Steel
Type*
(fixed point)**

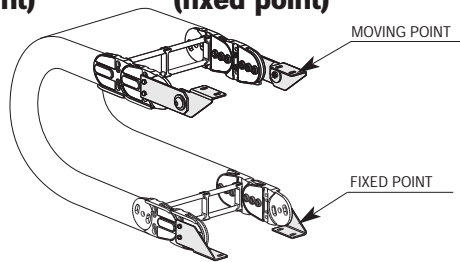
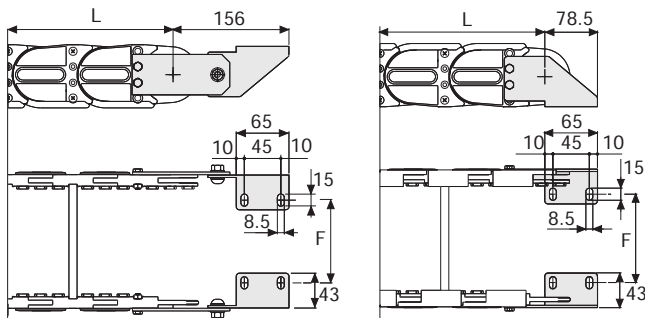

Fig. A
Chain fixed outside the radius. (Fig A)



Chain Type	F mm
SR328B100	87
SR328B150	137
SR328B200	187
SR328B250	237
SR328B300	287

Special dimension F=A-75

**Bright Zinc Plated Steel
Type Part Numbers**

Complete Set Assembled	
Chain Type	End Brackets Set
SR328B...	A328KM

Complete Set Unassembled	
Chain Type	End Brackets Set
SR328B...	A328K

*Available on request in stainless steel

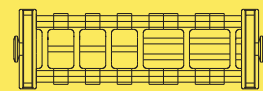

Supplementary movable separators.

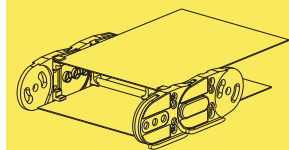

Steel laminar cover.

Special tool to remove the connecting pivots:
Part Number PZ038.



For further information please consult Brevetti Stendalto's Technical Office